

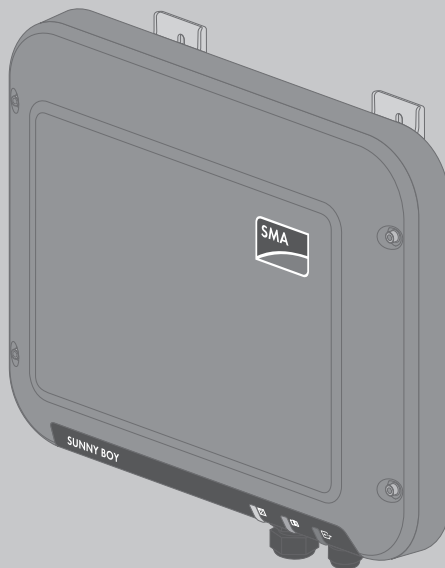

Operating Manual  
**SUNNY BOY 1.5 / 2.5**



## Legal Provisions

The information contained in these documents is property of SMA Solar Technology AG. Any publication, whether in whole or in part, requires prior written approval by SMA Solar Technology AG. Internal reproduction used solely for the purpose of product evaluation or other proper use is allowed and does not require prior approval.

### SMA Warranty

You can download the current warranty conditions from the Internet at [www.SMA-Solar.com](http://www.SMA-Solar.com).

### Trademarks

All trademarks are recognized, even if not explicitly identified as such. A lack of identification does not mean that a product or symbol is not trademarked.

The BLUETOOTH® word mark and logos are registered trademarks of Bluetooth SIG, Inc. and any use of these marks by SMA Solar Technology AG is under license.

Modbus® is a registered trademark of Schneider Electric and is licensed by the Modbus Organization, Inc.

QR Code is a registered trademark of DENSO WAVE INCORPORATED.

Phillips® and Pozidriv® are registered trademarks of Phillips Screw Company.

Torx® is a registered trademark of Acument Global Technologies, Inc.

### SMA Solar Technology AG

Sonnenallee 1

34266 Niestetal

Germany

[www.SMA.de](http://www.SMA.de)

© 2004 to 2015 SMA Solar Technology AG. All rights reserved.

# Table of Contents

<b>1</b>	<b>Information on this Document .....</b>	<b>5</b>
1.1	Validity .....	5
1.2	Target Group.....	5
1.3	Additional Information .....	5
1.4	Symbols .....	6
1.5	Nomenclature.....	6
1.6	Typographies.....	6
<b>2</b>	<b>Safety.....</b>	<b>7</b>
2.1	Intended Use .....	7
2.2	Safety Information.....	7
<b>3</b>	<b>Scope of Delivery.....</b>	<b>9</b>
<b>4</b>	<b>Product Description.....</b>	<b>10</b>
4.1	Sunny Boy.....	10
4.2	Interfaces and Functions .....	13
4.3	LED Signals .....	15
<b>5</b>	<b>Mounting .....</b>	<b>16</b>
5.1	Requirements for Mounting .....	16
5.2	Mounting the Inverter.....	18
<b>6</b>	<b>Electrical Connection.....</b>	<b>20</b>
6.1	Safety during Electrical Connection.....	20
6.2	Overview of the Connection Area .....	21
6.3	AC Connection.....	21
6.3.1	Requirements for the AC Connection.....	21
6.3.2	Connecting the Inverter to the Utility Grid.....	23
6.3.3	Connecting Additional Grounding .....	25
6.4	Connecting the Inverter to the Network .....	26
6.5	DC Connection.....	28
6.5.1	Requirements for the DC Connection.....	28
6.5.2	Assembling the DC Connectors .....	29
6.5.3	Connecting the PV Array.....	30

6.5.4	Disassembling the DC Connectors.....	31
<b>7</b>	<b>Commissioning the Inverter .....</b>	<b>33</b>
<b>8</b>	<b>Using the Inverter User Interface .....</b>	<b>34</b>
8.1	Calling Up the Inverter User Interface .....	34
8.1.1	Calling Up the Inverter User Interface via Direct Connection .....	34
8.1.2	Calling Up the Inverter User Interface in the Local Network .....	36
8.2	Design of the Inverter User Interface .....	37
8.3	Changing the Password.....	39
8.4	Forgotten Password.....	40
<b>9</b>	<b>Configuration .....</b>	<b>41</b>
9.1	Configuration Procedure.....	41
9.2	Starting the Installation Assistant.....	41
9.3	Starting the Self-Test (For Italy Only) .....	42
9.4	Activating the Receipt of Control Signals (Only for Italy).....	42
9.5	Deactivating Grounding Conductor Monitoring.....	43
9.6	Setting SMA OptiTrac Global Peak .....	43
9.7	Saving the Configuration in a File.....	44
9.8	Adopting a Configuration from a File.....	44
9.9	Updating the Firmware .....	44
9.10	Integrating the Inverter into the Network.....	45
9.11	Setting the Date and Device Time .....	45
9.12	Configuring the Energy Meter.....	45
9.13	Configuring Feed-In Management .....	46
9.14	Changing Operating Parameters.....	46
9.15	Configuring the Country Data Set.....	47
9.16	Switching the Dynamic Power Display Off.....	48
9.17	Switching WLAN Off.....	48
9.18	Switching WLAN On.....	48
<b>10</b>	<b>Disconnecting the Inverter from Voltage Sources.....</b>	<b>50</b>
<b>11</b>	<b>Technical Data.....</b>	<b>52</b>
<b>12</b>	<b>Contact.....</b>	<b>57</b>

# 1 Information on this Document

## 1.1 Validity

This document is valid for the following device types from firmware version 2.0.1.R:

- SB1.5-1VL-40 (Sunny Boy 1.5)
- SB2.5-1VL-40 (Sunny Boy 2.5)

## 1.2 Target Group

This document is intended for qualified persons and end users. Only qualified persons are allowed to perform the activities marked in this document with a warning symbol and the caption "Qualified person". Tasks that do not require any particular qualification are not marked and can also be performed by end users. Qualified persons must have the following skills:







- Knowledge of how an inverter works and is operated
- Training in how to deal with the dangers and risks associated with installing and using electrical devices and installations
- Training in the installation and commissioning of electrical devices and installations
- Knowledge of the applicable standards and directives
- Knowledge of and compliance with this document and all safety information

## 1.3 Additional Information

Links to additional information can be found at [www.SMA-Solar.com](http://www.SMA-Solar.com):

Document title	Document type
Troubleshooting, Cleaning and Decommissioning	Service Manual
"Efficiency and Derating" Efficiency and Derating Behavior of the Sunny Boy, Sunny Tripower and Sunny Mini Central Inverters	Technical Information
"Application for SMA Grid Guard Code"	Certificate
"Circuit Breaker" Dimensioning and Selection of a Suitable AC Circuit Breaker for Inverters under PV-Specific Influences	Technical Information
"Criteria for Selecting a Residual-Current Device"	Technical Information
"Temperature Derating" Causes of Temperature Derating and Possible Corrective Measures	Technical Information
"Overvoltage Protection" Measures For Lightning and Overvoltage Protection in PV Systems	Technical Information
"Webconnect Systems in Sunny Portal" Registration in Sunny Portal	User Manual

## 1.4 Symbols

Symbol	Explanation
	Indicates a hazardous situation which, if not avoided, will result in death or serious injury
	Indicates a hazardous situation which, if not avoided, can result in death or serious injury
	Indicates a hazardous situation which, if not avoided, can result in minor or moderate injury
	Indicates a situation which, if not avoided, can result in property damage
	Sections describing activities to be performed by qualified persons only
	Information that is important for a specific topic or goal, but is not safety-relevant
<input type="checkbox"/>	Indicates a requirement for meeting a specific goal
<input checked="" type="checkbox"/>	Desired result
	A problem that might occur

## 1.5 Nomenclature

Complete designation	Designation in this document
Sunny Boy	Inverter, product

## 1.6 Typographies

Typography	Use	Example
<b>bold</b>	<ul style="list-style-type: none"> <li>• Display texts</li> <li>• Elements on a user interface</li> <li>• Terminals</li> <li>• Elements to be selected</li> <li>• Elements to be entered</li> </ul>	<ul style="list-style-type: none"> <li>• The value can be found in the field <b>Energy</b>.</li> <li>• Select <b>Settings</b>.</li> <li>• Enter <b>10</b> in the field <b>Minutes</b>.</li> </ul>
>	<ul style="list-style-type: none"> <li>• Connects several elements to be selected</li> </ul>	<ul style="list-style-type: none"> <li>• Select <b>Settings &gt; Date</b>.</li> </ul>
[Button] [Key]	<ul style="list-style-type: none"> <li>• Button or key to be selected or pressed</li> </ul>	<ul style="list-style-type: none"> <li>• Select <b>[Next]</b>.</li> </ul>

## 2 Safety

### 2.1 Intended Use

The Sunny Boy is a transformerless PV inverter which converts the direct current of the PV array to grid-compliant alternating current and feeds it into the utility grid.

The product is suitable for indoor and outdoor use.

The product must only be operated with PV arrays of protection class II in accordance with IEC 61730, application class A. The PV modules must be compatible with this product.

PV modules with a high capacity to ground must only be used if their coupling capacity does not exceed 900 nF (for information on how to calculate the coupling capacity, see the Technical Information "Leading Leakage Currents" at [www.SMA-Solar.com](http://www.SMA-Solar.com)).

All components must remain within their permitted operating ranges at all times.

The product must only be used in countries for which it is approved or released by SMA Solar Technology AG and the grid operator.

Use this product only in accordance with the information provided in the enclosed documentation and with the locally applicable standards and directives. Any other application may cause personal injury or property damage.

Alterations to the product, e.g. changes or modifications, are only permitted with the express written permission of SMA Solar Technology AG. Unauthorized alterations will void guarantee and warranty claims and usually void the operation permit. SMA Solar Technology AG shall not be held liable for any damage caused by such changes.

Any use of the product other than that described in the Intended Use section does not qualify as appropriate.

The enclosed documentation is an integral part of this product. Keep the documentation in a convenient place for future reference and observe all instructions contained therein.

The type label must remain permanently attached to the product.

### 2.2 Safety Information

This section contains safety information that must be observed at all times when working on or with the product.

To prevent personal injury and property damage and to ensure long-term operation of the product, read this section carefully and observe all safety information at all times.

**⚠ DANGER****Danger to life due to high voltages of the PV array**

When exposed to sunlight, the PV array generates dangerous DC voltage which is present in the DC conductors and the live components of the inverter. Touching the DC conductors or the live components can lead to lethal electric shocks. If you disconnect the DC connectors from the inverter under load, an electric arc may occur leading to electric shock and burns.

- Do not touch non-insulated cable ends.
- Do not touch the DC conductors.
- Do not touch any live components of the inverter.
- Have the inverter mounted, installed and commissioned only by qualified persons with the appropriate skills.
- If an error occurs, have it rectified by qualified persons only.
- Prior to performing any work on the inverter, disconnect it from all voltage sources as described in this document (see Section 10 "Disconnecting the Inverter from Voltage Sources", page 50).

**⚠ DANGER****Danger to life due to high voltages in the inverter**

Touching live components within the inverter can lead to lethal electric shocks. Some components also require at least five minutes to discharge after the inverter has been disconnected from voltage sources.

- Do not open the inverter.

**⚠ DANGER****Danger to life due to electric shock**

Touching an ungrounded PV module or array frame can cause a lethal electric shock.

- Connect and ground the PV modules, array frame and electrically conductive surfaces so that there is continuous conduction. Observe the applicable local regulations.

**NOTICE****Damage to the inverter due to the use of cleaning agents**

- If the inverter is dirty, clean the enclosure, the enclosure lid, the type label and the LEDs using only clean water and a cloth.



### 3 Scope of Delivery

Check the scope of delivery for completeness and any externally visible damage. Contact your distributor if the scope of delivery is incomplete or damaged.

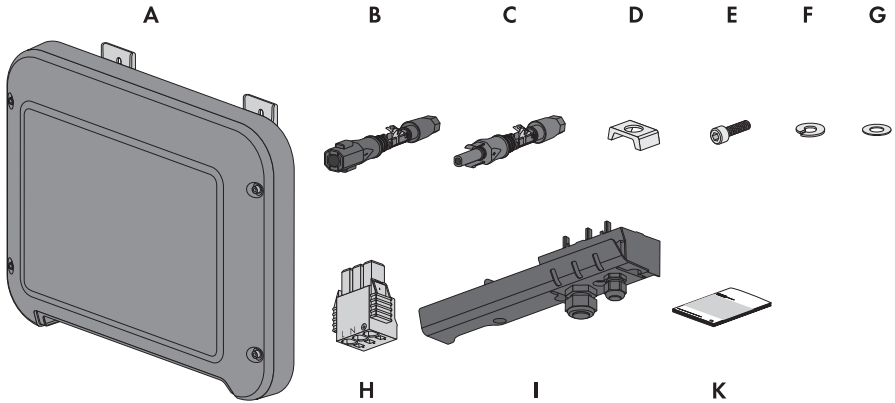

Figure 1: Components included in the scope of delivery

Position	Quantity	Designation
A	1	Inverter
B	1	Negative DC connector
C	1	Positive DC connector
D	1	Clamping bracket
E	1	Cylindrical screw M5 x 16
F	1	Spring lock washer
G	1	Washer
H	1	AC connector
I	1	Connection cap
K	1	Quick reference guide with password label on the rear side The label contains the following information: <ul style="list-style-type: none"> <li>• PIC (Product Identification Code) identification key for registering the PV system in Sunny Portal</li> <li>• RID (Registration Identifier) registration ID for registering the PV system in Sunny Portal</li> <li>• WLAN password WPA2-PSK (Wi-Fi Protected Access 2 - Preshared Key) for direct access to the inverter via WLAN</li> </ul>

## 4 Product Description

### 4.1 Sunny Boy

The Sunny Boy is a transformerless PV inverter which converts the direct current of the PV array to grid-compliant alternating current and feeds it into the utility grid.

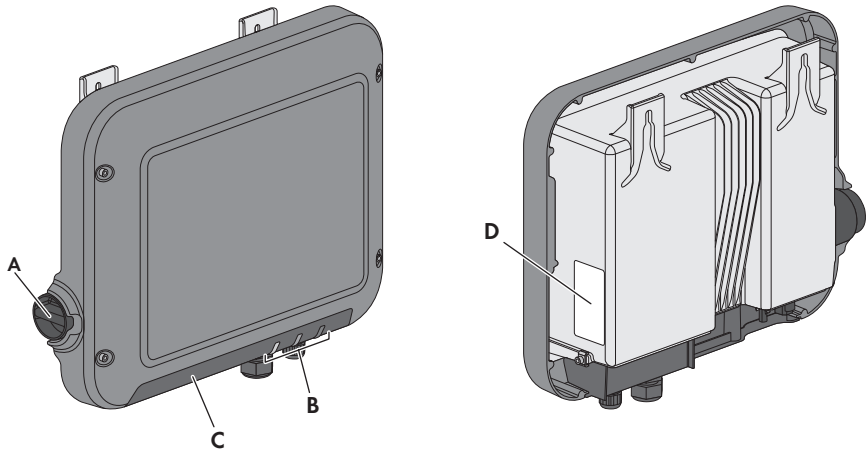

















Figure 2: Design of the Sunny Boy



Position	Designation
A	<p>DC Load-Break Switch</p> <p>The inverter is equipped with a DC load-break switch. If the DC load-break switch is set to the position I, it establishes a conductive connection between the PV array and the inverter. Setting the DC load-break switch to the <b>0</b> position interrupts the DC electric circuit and completely disconnects the PV array from the inverter. Disconnection takes place at all poles.</p>
B	<p>LEDs</p> <p>The LEDs indicate the operating state of the inverter.</p>

Position	Designation
C	<p>Connection cap</p> <p>Connection area with cable glands for connection to the utility grid and the local network</p>
D	<p>Type label</p> <p>The type label uniquely identifies the inverter. You will require the information on the type label to use the product safely and when seeking customer support from the SMA Service Line. The type label must remain permanently attached to the product. You will find the following information on the type label:</p> <ul style="list-style-type: none"> <li>• Device type (Model)</li> <li>• Serial number (Serial No.)</li> <li>• Date of manufacture</li> <li>• Identification key (PIC) for registration in Sunny Portal</li> <li>• registration ID (RID) for registration in Sunny Portal</li> <li>• WLAN password (WPA2-PSK) for direct access to the inverter via WLAN</li> <li>• Device-specific characteristics</li> </ul>

## Symbols on the Inverter and on the Type Label

Symbol	Explanation
	<p>Inverter</p> <p>Together with the green LED, this symbol indicates the operating state of the inverter</p>
	<p>Observe the documentation</p> <p>Together with the red LED, this symbol indicates an error (for information regarding troubleshooting, see the service manual at <a href="http://www.SMA-Solar.com">www.SMA-Solar.com</a>)</p>
	<p>Data transmission</p> <p>Together with the blue LED, this symbol indicates that the inverter has an active network connection</p>
	<p>Grounding conductor</p> <p>This symbol indicates the position for connecting a grounding conductor.</p>
	<p>Danger to life due to high voltages in the inverter; observe the waiting time of five minutes</p> <p>High voltages that can cause lethal electric shocks are present in the live components of the inverter. Prior to performing any work on the inverter, disconnect it from all voltage sources as described in this document (see Section 10, page 50).</p>

Symbol	Explanation
	Risk of burns due to hot surfaces The product can get hot during operation. Avoid contact during operation. Prior to performing any work on the product, allow the product to cool down sufficiently.
	Danger to life due to electric shock The product operates at high voltages. Prior to performing any work on the product, disconnect the product from voltage sources. All work on the product must be carried out by electrically qualified persons only.
	Observe the documentation Observe all documentation supplied with the product.
	Danger This symbol indicates that the inverter must be additionally grounded if additional grounding or equipotential bonding is required at the installation site (see Section 6.3.3 "Connecting Additional Grounding", page 25).
	Direct current
	The product does not have a transformer.
	Alternating current
	WEEE designation Do not dispose of the product together with the household waste but in accordance with the disposal regulations for electronic waste applicable at the installation site.
	CE marking The product complies with the requirements of the applicable EU directives.
	Degree of protection IP65 The product is protected against dust intrusion and water jets from any angle.

Symbol	Explanation
	The product is suitable for outdoor installation.
	RCM (Regulatory Compliance Mark) The product complies with the requirements of the applicable Australian standards.

## 4.2 Interfaces and Functions

The inverter is equipped with the following interfaces and functions:

### Web server with user interface for configuration

The inverter is equipped as standard with an integrated web server that enables configuration of the inverter via an individual user interface. The inverter user interface can be called up directly via the web browser in a computer, tablet PC or smartphone so long as there is a WLAN or Ethernet connection (see Section 8 "Using the Inverter User Interface", page 34).

### SMA Speedwire

The inverter is equipped with SMA Speedwire as standard. SMA Speedwire is a type of communication based on the Ethernet standard. This enables inverter-optimized 10/100 Mbit data transmission between Speedwire devices in PV systems and the inverter user interface.

### Webconnect

The inverter is equipped with a Webconnect function as standard. The Webconnect function enables direct data transmission between the inverters of a small-scale system and the Internet portal Sunny Portal without any additional communication device and for a maximum of four inverters per Sunny Portal system. In large-scale PV power plants, data transmission between inverters and the Internet portal Sunny Portal is carried out via the Sunny Home Manager. You can access your Sunny Portal system from any computer with an Internet connection.

Webconnect enables - for PV systems operated in Italy - the connection or disconnection of the inverter to or from the utility grid and the specifying of the frequency limits to be used via IEC61850-GOOSE messages.

### WLAN

The inverter is equipped with a WLAN interface as standard. The inverter is delivered with the WLAN interface activated as standard. If you do not want to use WLAN, you can deactivate the WLAN interface (see Section 9.17 "Switching WLAN Off", page 48). In addition, the inverter has a WPS (WiFi Protected Setup) function. The WPS function connects the inverter automatically with an end device (e.g. smartphone, tablet PC or computer). You can activate the WPS function by tapping on the enclosure lid twice in quick succession. The open interface will then be signaled via the rapid flashing of the blue LED on the inverter.

**i Limited function in the event of frost**

The integrated WLAN interface is only designed for temperatures down to -20 °C.

- Deactivate the WLAN interface at low temperatures (see Section 9.17 "Switching WLAN Off", page 48).

**Grid Management Services**

The inverter is equipped with service functions for grid management.

Depending on the requirements of the grid operator, you can activate and configure the functions (e.g. active power limitation) via operating parameters.

**SMA OptiTrac Global Peak**

SMA OptiTrac Global Peak is an advancement of SMA OptiTrac and allows the operating point of the inverter to follow the optimal operating point of the PV array (MPP) precisely at all times. In addition, with the aid of SMA OptiTrac Global Peak, the inverter detects several maximum power points in the available operating range, such as may occur particularly with partially shaded strings. SMA OptiTrac Global Peak is enabled by default.

**All-pole sensitive residual-current monitoring unit**

The all-pole sensitive residual-current monitoring unit detects alternating and direct differential currents. In single-phase and three-phase inverters, the integrated differential current sensor detects the current difference between the neutral conductor and the line conductor(s). If the current difference increases suddenly, the inverter disconnects from the utility grid.

**Connection of the SMA Energy Meter**

If an SMA Energy Meter is installed in the PV system, the inverter can receive data on the household energy consumption directly from this.

## 4.3 LED Signals

LED	Status	Explanation
Green LED	flashing	<p>Waiting for connection conditions</p> <p>The LED is on for two seconds and then off for two seconds. The conditions for feed-in operation are not yet met. As soon as the conditions are met, the inverter will start feed-in operation.</p>
	glowing	<p>Feed-in operation (Power: <math>\geq 90\%</math>, relative to the active power limit set)</p> <p>The inverter feeds in with a power of at least 90%.</p>
	pulsing	<p>Feed-in operation (Power: <math>&lt; 90\%</math>, relative to the active power limit set)</p> <p>The inverter feeds in with a power of less than 90%. The LED flashes on and off uniformly. The higher the power, the greater the frequency. If required, you can switch the dynamic power display off (see Section 9.16 "Switching the Dynamic Power Display Off", page 48).</p>
Red LED	glowing	<p>Error</p> <p>If an error occurs, a distinct error message and the corresponding event number will be displayed in addition on the inverter user interface or in the communication product. The error must be rectified by a qualified person (for troubleshooting, see the service manual at <a href="http://www.SMA-Solar.com">www.SMA-Solar.com</a>).</p>
Blue LED	flashes slowly for approx. one minute	<p>Communication connection is being established</p> <p>The inverter is establishing a connection to a local network or creating an Ethernet direct connection to an end device (e.g. smartphone, tablet PC or computer).</p>
	flashes slowly for approx. two minutes	<p>WPS active</p> <p>The WPS function of the inverter for WLAN direct connection with an end device (e.g. smartphone, tablet PC or computer) is active.</p>
	glowing	<p>Communication active</p> <p>There is an active connection with a local network or an Ethernet direct connection with an end device (e.g. smartphone, tablet PC or computer).</p>

## 5 Mounting

### 5.1 Requirements for Mounting

Requirements for the mounting location:

#### **⚠ WARNING**

##### **Danger to life due to fire or explosion**

Despite careful construction, electrical devices can cause fires.

- Do not mount the inverter in areas containing highly flammable materials or gases.
- Do not mount the inverter in a potentially explosive atmosphere.

- Do not mount the inverter on a pillar.
- A solid support surface must be available for mounting, e.g. concrete or masonry.
- The support surface must be even. The difference between the outer anchoring points must not exceed 5 mm.
- The mounting location must be suitable for the weight and dimensions of the inverter (see Section 11 "Technical Data", page 52).
- The mounting location should not be exposed to direct solar irradiation. Direct solar irradiation can cause the inverter to overheat. As a result, the inverter reduces its power output.
- The mounting location should be freely and safely accessible at all times without the need for any auxiliary equipment (such as scaffolding or lifting platforms). Non-fulfilment of these criteria may restrict servicing.
- To ensure optimum operation, the ambient temperature should be between -25°C and 40°C.
- Climatic conditions must be met (see Section 11 "Technical Data", page 52).



**Dimensions for mounting:**

Figure 3: Position of the anchoring points

**Recommended clearances:**

If you maintain the recommended clearances, adequate heat dissipation will be ensured. Thus, you will prevent power reduction due to excessive temperature.

- Maintain the recommended clearances to walls as well as to other inverters or objects.
- If multiple inverters are mounted in areas with high ambient temperatures, increase the clearances between the inverters and ensure sufficient fresh-air supply.

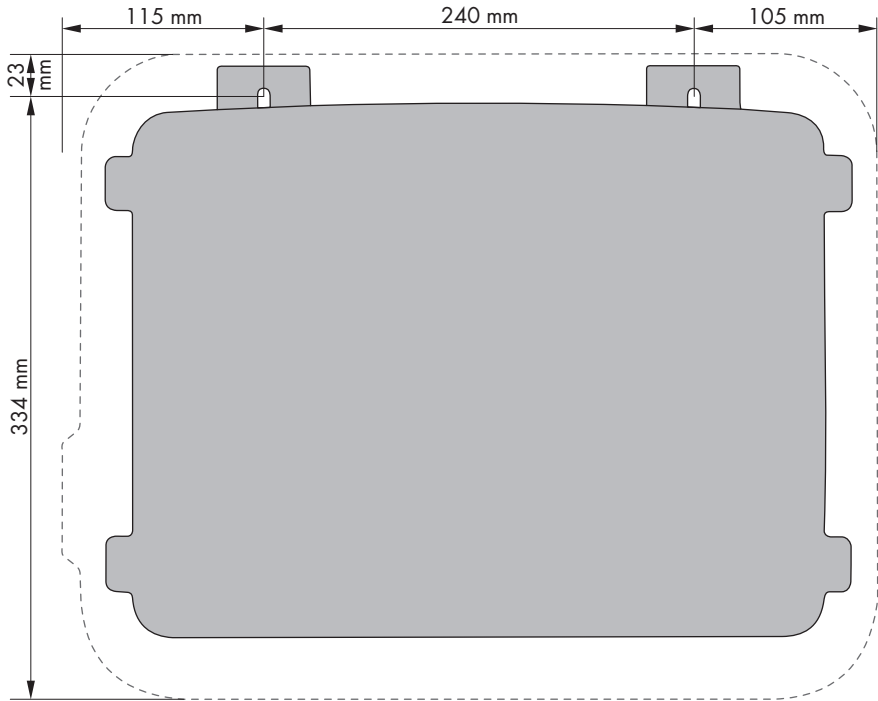
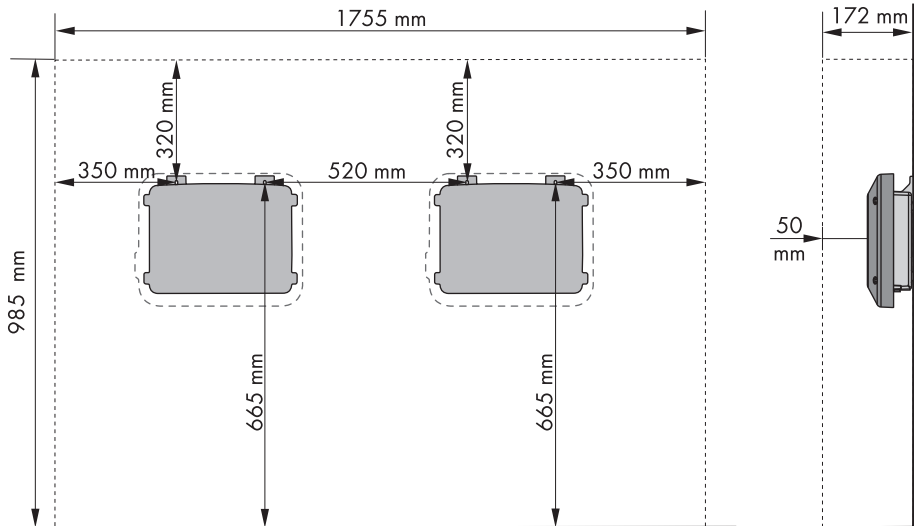

Figure 4: Recommended clearances

**Permitted and prohibited mounting positions:**

- The inverter must only be mounted in one of the permitted positions. This will ensure that no moisture can penetrate the inverter.
- The inverter should be mounted in such a way that LED signals can be read without difficulty.

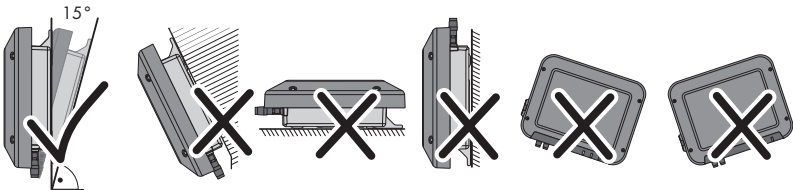

Figure 5: Permitted and prohibited mounting positions:

## 5.2 Mounting the Inverter

**▲ QUALIFIED PERSON****Additionally required mounting material (not included in the scope of delivery):**

- Two stainless steel hexagon head wood screws (AF 10, diameter 6 mm), screw length must be suitable for the support surface and the weight of the inverter (fastening bracket thickness: 4 mm)
- If necessary, two screw anchors suitable for the support surface and the screws

### ⚠ CAUTION

#### Risk of injury when lifting the inverter, or if it is dropped

The inverter weighs 9 kg. There is risk of injury if the inverter is lifted incorrectly or dropped while being transported or when attaching it to or removing it from the wall mounting bracket.

- Transport and lift the inverter carefully.

#### Procedure:

##### 1. ⚠ CAUTION

#### Risk of injury due to damaged cables

There may be power cables or other supply lines (e.g. gas or water) routed in the wall.

- Ensure that no lines are laid in the wall which could be damaged when drilling holes.

2. Mark the position of the drill holes. Use the information on dimensioning given in this document for this (see Section 5.1 "Requirements for Mounting", page 16).
3. Ensure that the positions marked are aligned horizontally.
4. Drill the holes at the positions marked.
5. If necessary, plug the screw anchors into the holes.
6. Screw the screws in so that there is still at least 6 mm distance between the screw head and the mounting surface.
7. Hang the inverter onto the screws using the metal brackets.

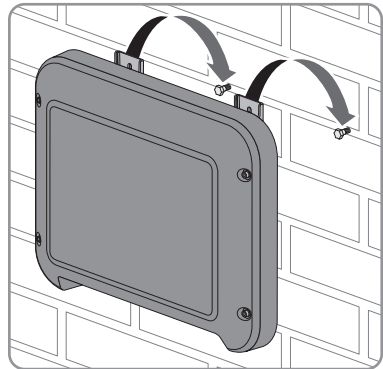

8. Tighten the screws hand-tight using a ratchet or box wrench. When doing this you can compensate for any misalignment of the drill holes by aligning the metal brackets accordingly.
9. Ensure that the inverter is securely in place.

## 6 Electrical Connection

### 6.1 Safety during Electrical Connection

#### **⚠ DANGER**

##### **Danger to life due to high voltages of the PV array**

When exposed to sunlight, the PV array generates dangerous DC voltage which is present in the DC conductors and the live components of the inverter. Touching the DC conductors or the live components can lead to lethal electric shocks. If you disconnect the DC connectors from the inverter under load, an electric arc may occur leading to electric shock and burns.

- Do not touch non-insulated cable ends.
- Do not touch the DC conductors.
- Do not touch any live components of the inverter.
- Have the inverter mounted, installed and commissioned only by qualified persons with the appropriate skills.
- If an error occurs, have it rectified by qualified persons only.
- Prior to performing any work on the inverter, disconnect it from all voltage sources as described in this document (see Section 10 "Disconnecting the Inverter from Voltage Sources", page 50).

#### **NOTICE**

##### **Damage to the seal of the enclosure lid in sub-zero conditions**

If you open the enclosure lid in sub-zero conditions, the sealing of the enclosure lid can be damaged. This can lead to moisture entering the inverter.

- Do not open the inverter at ambient temperatures lower than  $-5^{\circ}\text{C}$ .
- If a layer of ice has formed on the seal of the enclosure lid in sub-zero conditions, remove it prior to opening the inverter (e.g. by melting the ice with warm air). Observe the applicable safety regulations.

## 6.2 Overview of the Connection Area

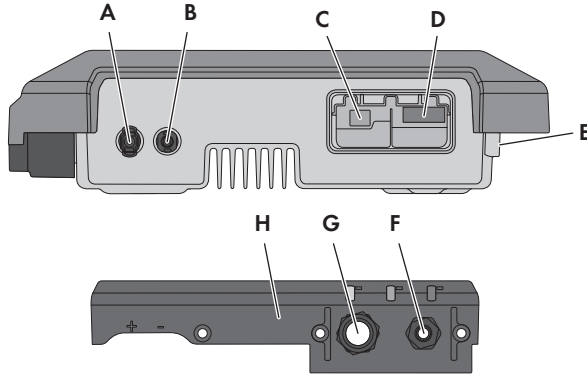

Figure 6: Connection areas and enclosure openings at the bottom of the inverter

Position	Designation
A	Positive DC connector
B	Negative DC connector
C	RJ45 pin connector for the network cable
D	Pin connector for the AC connector
E	Connection of the grounding terminal for additional grounding
F	Cable gland for the AC cable
G	Cable gland with filler plug for the network cable
H	Connection cap

## 6.3 AC Connection

### 6.3.1 Requirements for the AC Connection

#### Cable requirements:

- External diameter: 5 mm to 13 mm
- Conductor cross-section: 1.5 mm<sup>2</sup> to 4 mm<sup>2</sup>
- Insulation stripping length: 15 mm

- Sheath stripping length: 70 mm
- The cable must be dimensioned in accordance with the local and national directives for the dimensioning of cables. The requirements for the minimum wire size derive from these directives. Examples of factors influencing cable dimensioning are: nominal AC current, type of cable, routing method, cable bundling, ambient temperature and maximum desired line losses (for calculation of line losses, see the design software "Sunny Design" from software version 2.0 at [www.SMA-Solar.com](http://www.SMA-Solar.com)).

#### Load-break switch and cable protection:

##### **NOTICE**

#### **Damage to the inverter due to the use of screw-type fuses as load-break switches**

Screw-type fuses (e.g. DIAZED fuse or NEOZED fuse) are not load-break switches.

- Do not use screw-type fuses as load-break switches.
- Use a load-break switch or circuit breaker as a load disconnection unit (for information and design examples, see the Technical Information "Circuit Breaker" at [www.SMA-Solar.com](http://www.SMA-Solar.com)).

- In PV systems with multiple inverters, protect each inverter with a separate circuit breaker. Make sure to observe the maximum permissible fuse protection (see Section 11 "Technical Data", page 52). This will prevent residual voltage being present at the corresponding cable after disconnection.
- Loads installed between the inverter and the circuit breaker must be fused separately.

#### Residual-current monitoring unit:

- If an external residual-current device is required, install a residual-current device which trips at a residual current of 100 mA or higher (for details on selecting a residual-current device, see the Technical Information "Criteria for Selecting a Residual-Current Device" at [www.SMA-Solar.com](http://www.SMA-Solar.com)).

#### Overvoltage category:

The inverter can be used in grids of overvoltage category III or lower in accordance with IEC 60664-1. That means that the inverter can be permanently connected to the grid-connection point of a building. In case of installations with long outdoor cabling routes, additional measures to reduce overvoltage category IV to overvoltage category III are required (see the Technical Information "Overvoltage Protection" at [www.SMA-Solar.com](http://www.SMA-Solar.com)).

#### Grounding conductor monitoring:

The inverter is equipped with a grounding conductor monitoring device. This grounding conductor monitoring device detects when there is no grounding conductor connected and disconnects the inverter from the utility grid if this is the case. Depending on the installation site and grid configuration, it may be advisable to deactivate the grounding conductor monitoring. This is necessary, for example, in an IT system if there is no neutral conductor present and you intend to install the inverter between two line conductors. If you are uncertain about this, contact your grid operator or SMA Solar Technology AG.

- Grounding conductor monitoring must be deactivated after initial start-up depending on the grid configuration (see Section 9.5, page 43).

### **i** Safety in accordance with IEC 62109 when the grounding conductor monitoring is deactivated

In order to guarantee safety in accordance with IEC 62109 when the grounding conductor monitoring is deactivated, carry out one of the following measures:

- Connect an additional grounding that has at least the same cross-section as the connected grounding conductor to the connecting terminal plate for the AC cable (see Section 6.3.3, page 25). This prevents touch current if the grounding conductor at the connecting terminal plate for the AC cable fails.

### **i** Connection of additional grounding

In some countries, additional grounding is generally required. In each case, observe the locally applicable regulations.

- If additional grounding is required, connect an additional grounding that has at least the same cross-section as the connected grounding conductor to the connecting terminal plate for the AC cable (see Section 6.3.3, page 25). This prevents touch current if the grounding conductor at the connecting terminal plate for the AC cable fails.

## 6.3.2 Connecting the Inverter to the Utility Grid

### **⚠ QUALIFIED PERSON**

#### Requirements:

- Only the AC connector supplied may be used.
- The connection requirements of the grid operator must be met.
- The grid voltage must be in the permissible range. The exact operating range of the inverter is specified in the operating parameters.

#### Procedure:

1. Disconnect the circuit breaker and secure it against reconnection.
2. Unscrew the swivel nut from the cable gland for the AC connection.

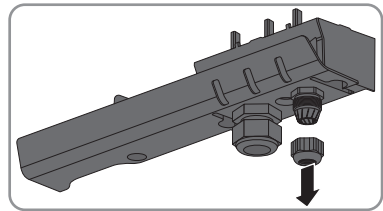

3. Thread the swivel nut over the AC cable.

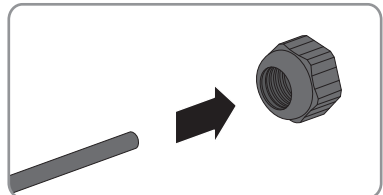

4. Thread the AC cable through the cable gland.

- If the external diameter of the cable is between 5 mm and 7 mm, thread the cable through the cable gland directly.
- If the external diameter of the cable is between 8 mm and 13 mm, first remove the inner sealing ring from the cable gland and then thread the cable through the cable gland. When doing so, ensure that the outer sealing ring is positioned correctly in the cable gland.

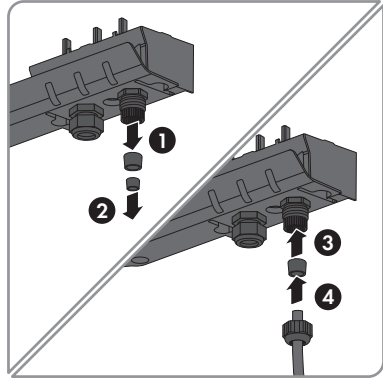
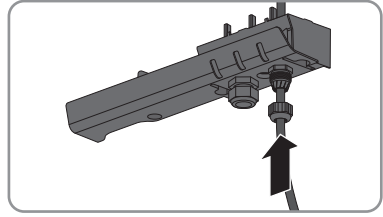

5. Dismantle 70 mm of the AC cable.
6. Shorten both L and N by 5 mm respectively, in order that the grounding conductor is the last to become detached in the event of tension.
7. Strip 15 mm of the insulation of L, N and the grounding conductor.
8. Connect L, N and the grounding conductor to the connecting terminal plate of the supplied AC plug in accordance with the labeling. When doing so, ensure that the conductors are plugged completely into the terminal up to the insulation.
 

Tip: To detach the conductors, plug a flat-blade screwdriver (blade width: 3 mm) into the rectangular openings positioned behind them.

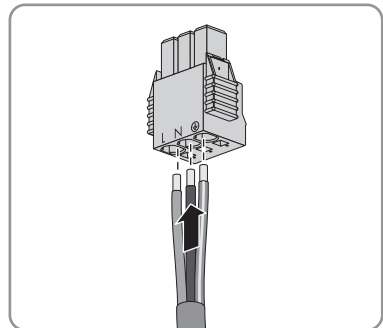

9. Make sure that all conductors are securely in place.



10. Plug the AC connector into the pin connector in the inverter until it snaps into place.

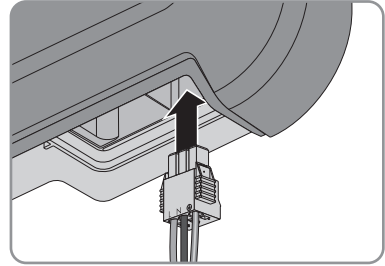

11. Check to ensure that the AC connector is securely in place by pulling lightly on the AC connector.
12. Tighten the swivel nut slightly.
13. If you would like to integrate the inverter into a local network via Ethernet, connect the inverter now (see Section 6.4, page 26).
14. Attach the connection cap to the inverter using the three screws and a Torx screwdriver (TX20) (torque: 3.5 Nm).

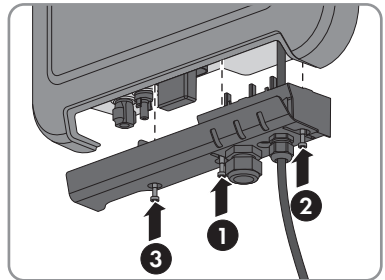

15. Tighten the swivel nut hand-tight.

### 6.3.3 Connecting Additional Grounding

#### **⚠ QUALIFIED PERSON**

If additional grounding or equipotential bonding is required locally, you can connect additional grounding to the inverter. This prevents touch current if the grounding conductor at the terminal for the AC cable fails.

The required clamping bracket, the cylindrical screw M5x16, the washer and the spring lock washer are part of the scope of delivery of the inverter.

#### **Cable requirements:**

##### **i Use of fine-stranded conductors**

You can use an inflexible or a flexible, fine-stranded conductor.

- When using a fine-stranded conductor, it has to be double crimped by a ring terminal lug. Make sure that no insulated conductor is visible when pulling or bending. This will ensure sufficient strain relief by means of the ring terminal lug.

- Grounding cable cross-section: max. 10 mm<sup>2</sup>

**Procedure:**

1. Strip off 12 mm of the grounding cable insulation.
2. Thread the screw through the spring lock washer, the clamping bracket and the washer.
3. Screw the screw into the thread slightly.
4. Lead the grounding cable between the washer and clamping bracket and tighten the screw (torque: 6 Nm) using a Torx screwdriver (TX25).

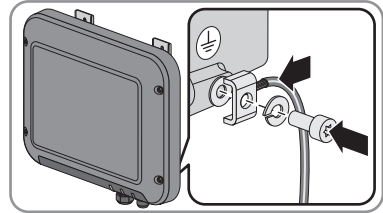

## 6.4 Connecting the Inverter to the Network

### **⚠ QUALIFIED PERSON**

#### **Additionally required material (not included in the scope of delivery):**

- One network cable
- Where required: Field-assembly RJ45 connector. SMA Solar Technology AG recommends the connector "MFP8 T568 A Cat.6A" from "Telegärtner".
- When laying the network cable outdoors: Overvoltage protection of the installation between the network cable from the inverter and the local network in the building. The overvoltage protection prevents overvoltages from being conducted via the network cable into the building and to other network devices in the event of a lightning strike.

#### **Cable requirements:**

The cable length and quality affect the quality of the signal. Observe the following cable requirements.

- Cable type: 100BaseTx
- Cable category: Cat5, Cat5e, Cat6, Cat6a or Cat7
- Plug type: RJ45 of Cat5, Cat5e, Cat6 or Cat6a
- Shielding: SF/UTP, S/UTP, SF/FTP or S/FTP
- Number of insulated conductor pairs and insulated conductor cross-section: at least  $2 \times 2 \times 0.22 \text{ mm}^2$
- Maximum cable length between two nodes when using patch cables: 50 m
- Maximum cable length between two nodes with installation cable: 100 m
- UV-resistant for outdoor use

#### **Procedure:**

1. **⚠ DANGER**

#### **Danger to life due to electric shock**

- If the inverter is already in operation, disconnect the inverter from voltage sources (see Section 10, page 50).

2. When using a self-assembly network cable, assemble the RJ45 connector and connect to the network cable (see connector documentation).
3. Remove the swivel nut from the cable gland for the network connection on the connection cap.
4. Thread the swivel nut over the network cable.
5. Remove the seal insert from the cable gland.
6. Remove one filler plug from the seal insert.
7. Push the network cable into the side slot in the seal insert.

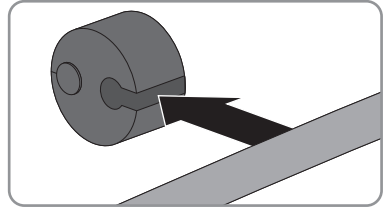

8. Thread the network cable through the cable gland.
9. Plug the network connector into the pin connector in the inverter until it snaps into place.

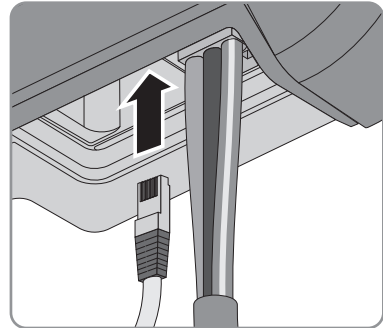

10. Ensure that the network connector is securely in place by pulling slightly on the cable.
11. Push the seal insert back into the cable gland.

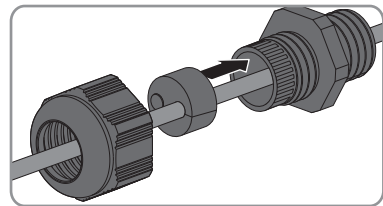

12. Tighten the swivel nut slightly.

13. Attach the connection cap to the inverter using the three screws and a Torx screwdriver (TX20) (torque: 3.5 Nm).

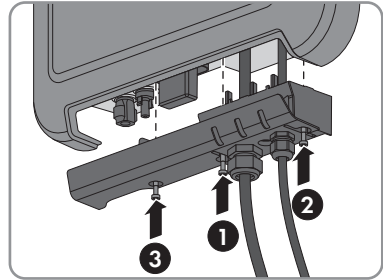

14. Tighten the swivel nuts of the AC cable gland and network connection hand-tight.  
 15. If the inverter is installed outdoors, install overvoltage protection.  
 16. Connect the other end of the network cable directly to the computer or router or connect it to another node. You can only connect the inverter to other nodes via star topology.

## 6.5 DC Connection

### 6.5.1 Requirements for the DC Connection

#### Requirements for the PV modules of a string:

- All PV modules must be of the same type.
- All PV modules must be aligned identically.
- All PV modules must have the same tilt angle.
- The thresholds for the input voltage and the input current of the inverter must be adhered to (see Section 1.1 "Technical Data", page 52).
- On the coldest day based on statistical records, the open-circuit voltage of the PV array must never exceed the maximum input voltage of the inverter.

#### **i** Use of Y adapters for parallel connection of strings

The Y adapters must not be used to interrupt the DC circuit.

- Do not use the Y adapters in the immediate vicinity of the inverter. The adapters must not be visible or freely accessible.
- In order to interrupt the DC circuit, always disconnect the inverter as described in this document (see Section 10 "Disconnecting the Inverter from Voltage Sources", page 50).

## 6.5.2 Assembling the DC Connectors

### ⚠ QUALIFIED PERSON

For connection to the inverter, all PV module connection cables must be fitted with the DC connectors provided. Assemble the DC connectors as described in the following. Be sure to observe the correct polarity. The DC connectors are marked with the symbols "+" and "-".

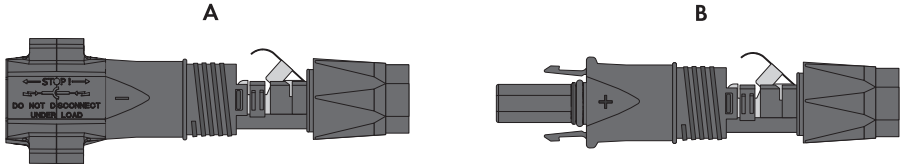

Figure 7: Negative (A) and positive (B) DC connectors

#### Cable requirements:

- Cable type: PV1-F, UL-ZKLA, USE2
- External diameter: 5 mm to 8 mm
- Conductor cross-section: 2.5 mm<sup>2</sup> to 6 mm<sup>2</sup>
- Qty single wires: minimum 7
- Nominal voltage: minimum 1,000 V

### ⚠ DANGER

#### Danger to life due to high voltages on DC conductors

When exposed to sunlight, the PV array generates dangerous DC voltage which is present in the DC conductors. Touching the DC conductors can lead to lethal electric shocks.

- Cover the PV modules.
- Do not touch the DC conductors.

#### Procedure:

1. Strip 12 mm of the cable insulation.
2. Insert the stripped cable into the DC connector up to the stop. When doing so, ensure that the stripped cable and the DC connector are of the same polarity.
3. Press the clamping bracket down until it audibly snaps into place.

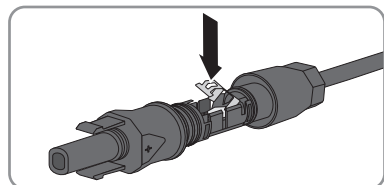
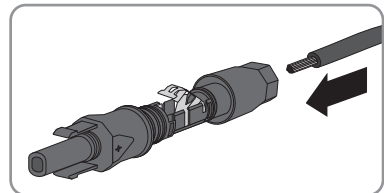

- ☑ The stranded wire can be seen inside the clamping bracket chamber.

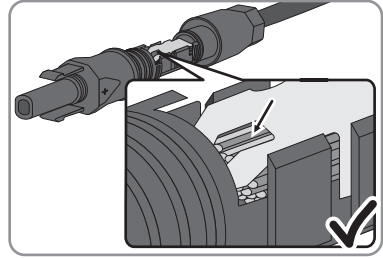

- ✘ The stranded wire cannot be seen in the chamber?

The cable is not correctly in place.

- Release the clamping bracket. To do so, insert a screwdriver (blade width: 3.5 mm) into the clamping bracket and pry the clamping bracket open.

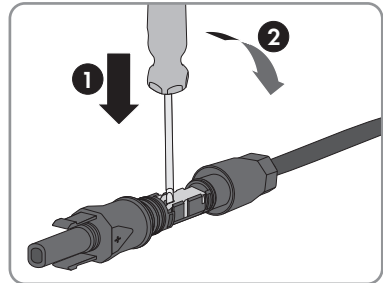

- Remove the cable and go back to step 2.

4. Push the swivel nut up to the thread and tighten (torque: 2 Nm).

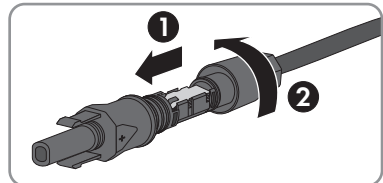

### 6.5.3 Connecting the PV Array

#### ⚠ QUALIFIED PERSON

##### NOTICE

#### Damage to the DC connectors due to the use of contact cleaner of other cleaning agents

Some contact cleaners or other cleaning agents may contain substances that decompose the plastic of the DC connectors.

- Do not use contact cleaners or other cleaning agents for cleaning the DC connectors.

1. Ensure that the circuit breaker is switched off and that it cannot be reconnected.
2. If an external DC load-break switch is installed, disconnect the external DC load-break switch from all voltage sources.

- Set the DC load-break switch of the inverter to position **O**.

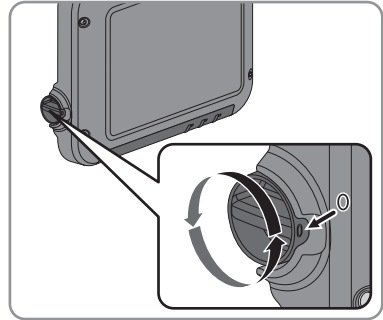

- Measure the PV array voltage. Ensure that the maximum input voltage of the inverter is adhered to and that there is no ground fault in the PV array.
- Check whether the DC connectors have the correct polarity.  
If the DC connector is equipped with a DC cable of the wrong polarity, the DC connector must be reassembled. The DC cable must always have the same polarity as the DC connector.
- Connect the assembled DC connectors to the inverter.

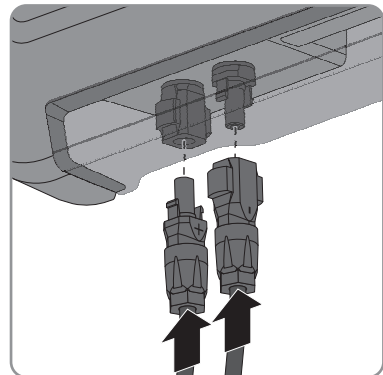

- The DC connectors snap into place.

- Ensure that all DC connectors are securely in place.

### 6.5.4 Disassembling the DC Connectors

#### **⚠ QUALIFIED PERSON**

#### **⚠ DANGER**

#### **Danger to life due to high voltages on DC conductors**

When exposed to sunlight, the PV array generates dangerous DC voltage which is present in the DC conductors. Touching the DC conductors can lead to lethal electric shocks.

- Cover the PV modules.
- Do not touch the DC conductors.

To disassemble the DC connectors, proceed as follows.

**Procedure:**

1. Set the DC load-break switch of the inverter to position **O**.
2. Release and remove all DC connectors. To do this, insert a flat-blade screwdriver or an angled screwdriver (blade width 3.5 mm) into one of the slide slots and pull the DC connectors out in a downward direction. Do not pull on the cable.

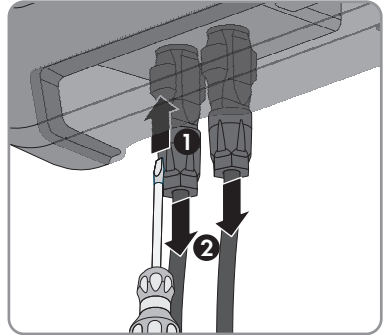

3. Remove the DC connector swivel nut.

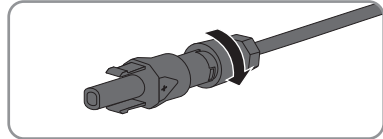

4. Unlock the DC connector. To do this, insert a flat-blade screwdriver (blade width: 3.5 mm) into the side catch mechanism and pry the catch mechanism open.

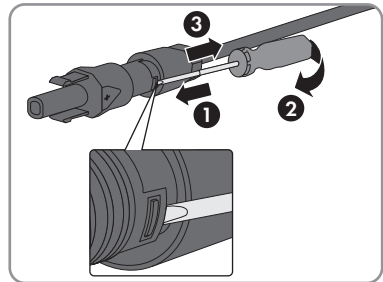

5. Carefully pull the DC connector apart.
6. Release the clamping bracket. To do so, insert a flat-blade screwdriver (blade width: 3.5 mm) into the clamping bracket and pry the clamping bracket open.

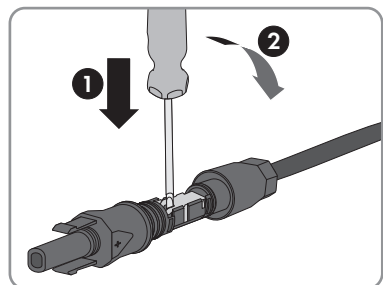

7. Remove the cable.



## 7 Commissioning the Inverter

### ⚠ QUALIFIED PERSON

#### Requirements:

- The inverter must be correctly mounted.
- The circuit breaker must be correctly rated.
- All cables must be correctly connected.
- A computer with a WLAN- or Ethernet interface or a tablet PC or smartphone with a WLAN interface must be available.

#### Procedure:

1. Turn the DC load-break switch of the inverter to position I.

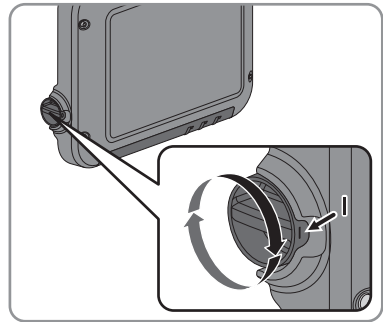

2. Switch on the circuit breaker.
  - The green LED flashes for approx. 30 seconds and then glows permanently or pulses.  
Feed-in operation begins.
  - The green LED is still flashing after one minute?  
The DC input voltage is still too low.
    - Once the DC input voltage is sufficiently high, feed-in operation begins.
  - The red LED is glowing?  
An error has occurred.
    - Rectify the error (see service manual at [www.SMA-Solar.com](http://www.SMA-Solar.com)).
3. Configure the inverter via the user interface (see Section 8.1.1 "Calling Up the Inverter User Interface via Direct Connection", page 34). When doing so you can either configure the inverter manually, use the installation assistant or adopt an existing configuration from a file. SMA Solar Technology AG recommends configuration with the help of the installation assistant.

## 8 Using the Inverter User Interface

### 8.1 Calling Up the Inverter User Interface

#### 8.1.1 Calling Up the Inverter User Interface via Direct Connection

You can call up the inverter user interface outside of a network via a direct connection between computer, tablet PC or smartphone and the inverter. There are two methods available for this:

- Direct connection via WLAN
- Direct connection via Ethernet

##### **i** Inverter SSID and IP address and necessary passwords

- Inverter SSID in WLAN: SMA[serial number] (e.g. SMA2130019815)
- Standard WLAN password: SMA12345 (usable for initial configuration prior to completion of the first ten operating hours)
- Device-specific WLAN password: see WPA2-PSK on the inverter type label or the rear side of the Quick Installation Guide included in delivery
- Standard inverter IP address for direct connection via WLAN outside of a local network: 192.168.100.1
- Standard inverter IP address for direct connection via Ethernet outside of a local network: 169.254.100.1

#### Direct connection via WLAN

##### Requirements:

- The inverter must be commissioned.
- A smartphone, tablet PC or computer with WLAN interface must be available.
- One of the following web browsers must be installed: Firefox (as of version 32), Internet Explorer (as of version 10), Safari (as of version 6) or Google Chrome (as of version 32).
- The personal SMA Grid Guard code of the Installer must be available for the changing of grid-relevant settings after completion of the first ten operating hours (see certificate "Application for SMA Grid Guard Code" at [www.SMA-Solar.com](http://www.SMA-Solar.com)).

##### **i** File export via Safari web browser not possible

When using the Safari web browser, the exporting of files (e.g. saving the current inverter configuration or exporting events) is not possible for technical reasons.

- Use a different supported web browser.

##### Procedure:

1. If your smartphone, tablet PC or computer has a WPS function:
  - Tap twice on the lid of the inverter to activate the inverter WPS function.
    - The inverter signals the open interface via the rapid flashing of the blue LED.

- Activate the WPS on your device.
  - The connection with your device will be established automatically. Please note that establishment of the connection to devices with Windows 7 or 8.1 can take up to 20 seconds.
- 2. If your smartphone, tablet PC or computer does not have a WPS function:
  - Search for WLAN networks with your device.
  - Select the inverter SSID **SMA[serial number]**.
  - Enter the inverter WLAN password. Within the first ten operating hours and prior to closing the installation assistant for the first time, you can use the standard WLAN password **SMA12345**. After this, you must use the device-specific inverter WLAN password (WPA2-PSK), which is printed on the type label and the rear side of the Quick Installation Guide included in delivery.
- 3. Enter **192.168.100.1** in the address line of the web browser and press the enter key.
  - The login page of the user interface opens.
- 4. Log in as **Installer** or **User**. A new password must be assigned upon logging in for the first time. To configure the inverter for the first time, login as an **Installer**.
- 5. Configure the inverter as desired.

## Direct connection via Ethernet

### Requirements:

- The inverter must be commissioned.
- A computer with an Ethernet interface must be available.
- One of the following web browsers must be installed: Firefox (as of version 32), Internet Explorer (as of version 10), Safari (as of version 6) or Google Chrome (as of version 32).
- The inverter must be connected directly to a computer.
- The personal SMA Grid Guard code of the Installer must be available for the changing of grid-relevant settings after completion of the first ten operating hours (see certificate "Application for SMA Grid Guard Code" at [www.SMA-Solar.com](http://www.SMA-Solar.com)).

### File export via Safari web browser not possible

When using the Safari web browser, the exporting of files (e.g. saving the current inverter configuration or exporting events) is not possible for technical reasons.

- Use a different supported web browser.

### Procedure:

1. Enter **169.254.100.1** in the address line of the web browser and press the enter key.
  - The login page of the user interface opens.
2. Log in as **Installer** or **User**. A new password must be assigned upon logging in for the first time. The initial configuration of the inverter may only be performed by a qualified person. In this case, login as an **Installer**.
3. Configure the inverter as desired.

## 8.1.2 Calling Up the Inverter User Interface in the Local Network

If the inverter has been integrated into a local network, you can call up the inverter user interface as described in the following:

### **i** New IP address with integration in a local network

The inverter receives a new IP address when it is integrated into the local network. Depending on the type of configuration, the new IP address will be assigned automatically by the DHCP server (router) or manually by you. Upon completion of the configuration, the inverter is only reachable via this new IP address or the alternative addresses.

Inverter access addresses:

- Generally applicable access address, e.g. for android products: IP address manually assigned or assigned by the DHCP server (router) (identification via SMA Connection Assist, network scanner software or router manual).
- Alternative access address for Apple products: SMA[serial number].local (e.g. SMA2130019815.local)
- Alternative access address for certain Windows products: SMA[serial number] (e.g. SMA2130019815)

### Requirements:

- Depending on the type of communication, a smartphone or tablet PC with WLAN interface or a computer with Ethernet connection or WLAN interface must be available.
- The computer, the tablet PC or the smartphone must be connected with the local network, e.g. via a router.
- One of the following web browsers must be installed: Firefox (as of version 32), Internet Explorer (as of version 10), Safari (as of version 6) or Google Chrome (as of version 32).
- The inverter must be connected via WLAN or Ethernet to the local network, e.g. via a router.
- The inverter access address must be known.
- The personal SMA Grid Guard code of the Installer must be available for the changing of grid-relevant settings after completion of the first ten operating hours (see certificate "Application for SMA Grid Guard Code" at [www.SMA-Solar.com](http://www.SMA-Solar.com)).

### **i** File export via Safari web browser not possible

When using the Safari web browser, the exporting of files (e.g. saving the current inverter configuration or exporting events) is not possible for technical reasons.

- Use a different supported web browser.

### Procedure:

1. Enter the inverter access address in the address line of the web browser and press the enter key.
  - The login page of the user interface opens.
2. Log in as **Installer** or **User**.

## 8.2 Design of the Inverter User Interface

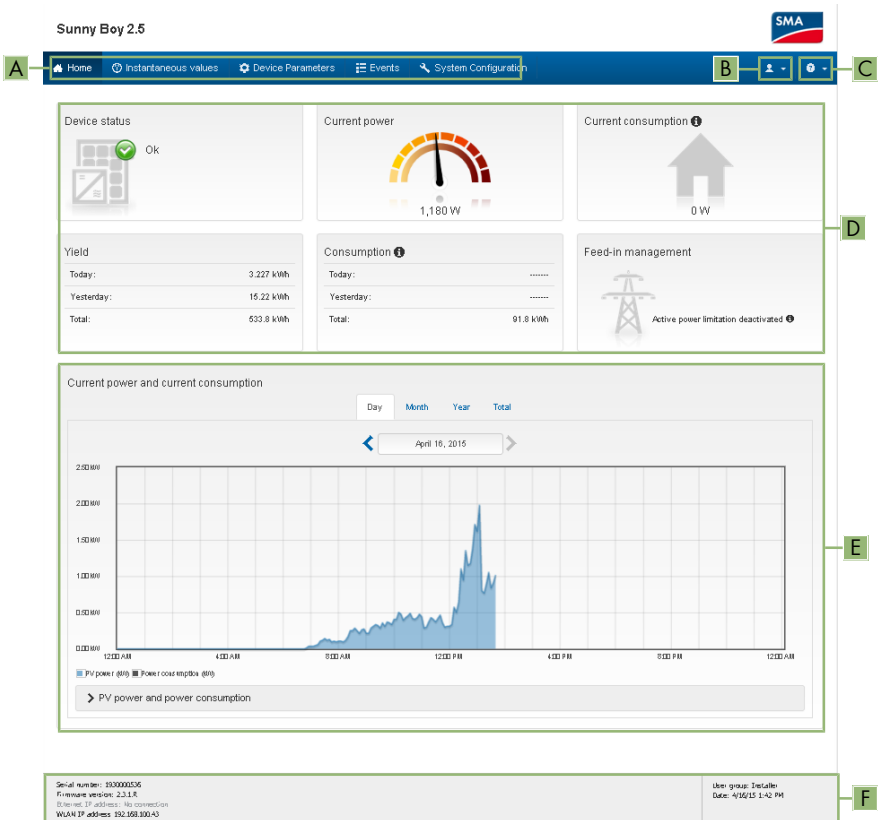

Figure 8: Design of the Inverter User Interface

Position	Designation	Description
A	Menu	<p>Provides the following functions:</p> <ul style="list-style-type: none"> <li>• <b>Home</b> Opens the user interface homepage</li> <li>• <b>Instantaneous values</b> Current measured values of the inverter</li> <li>• <b>Device Parameters</b> The various operating parameters of the inverter can be viewed and configured here depending on the user group.</li> <li>• <b>Events</b> All events that have occurred in the selected time period are displayed here. The event types are <b>Information</b>, <b>Warning</b> and <b>Error</b>. Currently existing events of the types <b>Error</b> and <b>Warning</b> will be additionally displayed in the <b>Device status</b> viewlet. However, only the higher-priority event is displayed. If, for example, there is a Warning and an Error present at the same time, only the Error will be displayed.</li> <li>• <b>System Configuration</b> The following settings for the inverter can be performed here. The selection is, however, dependent on the user group logged in and the set country data set. <ul style="list-style-type: none"> <li>- Changing the device name</li> <li>- Updating the firmware</li> <li>- Saving the configuration in a file</li> <li>- Adopting the configuration from a file</li> <li>- Starting the self-test</li> </ul> </li> </ul>
B	User settings	<p>Provides the following functions, depending on the user group logged in:</p> <ul style="list-style-type: none"> <li>• Start the installation assistant</li> <li>• SMA Grid Guard login</li> <li>• Logout</li> </ul>
C	Help	<p>Provides the following functions:</p> <ul style="list-style-type: none"> <li>• Displaying information on Open Source licenses used</li> <li>• With an internet connection: opening the product page of the inverter</li> <li>• With an internet connection: downloading the inverter manual</li> </ul>

Position	Designation	Description
D	Status display	<p>The various areas display information on the current status of the PV system.</p> <ul style="list-style-type: none"> <li>• <b>Device status</b> Displays whether the inverter is currently in a fault-free operating state or whether there is an Error or Warning present.</li> <li>• <b>Current power</b> Displays the power currently being generated by the inverter.</li> <li>• <b>Current consumption</b> Displays the current consumption of the household if an energy meter is installed in the PV system.</li> <li>• <b>Yield</b> Displays the energy yield of the inverter.</li> <li>• <b>Consumption</b> Displays the energy consumption of the household if an energy meter is installed in the PV system.</li> <li>• <b>Feed-in management</b> Displays whether the inverter is currently limiting its active power.</li> </ul>
E	PV power and power consumption progression	<p>Temporal progression of the PV power and the power consumption of the household over the selected time period. Please note, the power consumption will only be displayed if an energy meter is installed in the PV system.</p>
F	Status bar	<p>Displays the following information:</p> <ul style="list-style-type: none"> <li>• Inverter serial number</li> <li>• Inverter firmware version</li> <li>• IP address of the inverter within the local network</li> <li>• User group logged in</li> <li>• Date and device time of the inverter</li> </ul>

## 8.3 Changing the Password

The password for the inverter can be changed for both user groups. Furthermore, the user group **Installer** can change the password for the user group **User** as well as its own password.

### **i** PV systems registered in a communication product

With PV systems that are registered in a communication product (e.g. Sunny Portal, Sunny Home Manager), you can also assign a new password for the user group **Installer** via the communication product. The password for the user group **Installer** is also the system password for the PV system. If you assign a password for the user group **Installer** on the inverter user interface that does not correspond to the system password, the inverter can no longer be reached by the communication product.

- Ensure that the password for the user group **Installer** is the same as the system password in the communication product.

#### **Procedure:**

1. Call up the inverter user interface (see Section 8.1, page 34).
2. Log in as **Installer** or **User**.
3. Call up the menu **Device Parameters**.
4. Select **[Edit parameters]**.
5. In the parameter group **User Rights > Access Control** change the password of the desired user group.
6. Select **[Save all]** to save the changes.

## 8.4 Forgotten Password

If you have forgotten the password for the inverter, you can unlock the inverter with a Personal Unlocking Key (PUK). For each inverter, there is one PUK for each user group (**User** and **Installer**).

Tip: With PV systems in Sunny Portal, you can also assign a new password via Sunny Portal for the user group **Installer**. The password for the user group **Installer** is the same as the system password in Sunny Portal.

#### **Procedure:**

1. Request PUK (application form available at [www.SMA-Solar.com](http://www.SMA-Solar.com)).
2. Call up the inverter user interface (see Section 8.1, page 34).
3. Enter the PUK instead of the password when registering on the user interface.
4. Call up the menu **Device Parameters**.
5. Select **[Edit parameters]**.
6. In the parameter group **User Rights > Access Control** change the password of the desired user group.
7. Select **[Save all]** to save the changes.

### **i** PV Systems in Sunny Portal

The password for the user group **Installer** is also the system password for the PV system in Sunny Portal. Changing the password of the user group **Installer** can lead to the inverter no longer being able to be reached by Sunny Portal.

- Assign the changed password of the user group **Installer** as the new system password in Sunny Portal (see the Sunny Portal user manual at [www.SMA-Solar.com](http://www.SMA-Solar.com)).



## 9 Configuration

### 9.1 Configuration Procedure

Once you have commissioned the inverter, you may have to adjust various inverter settings. This section describes the procedure for configuration and gives an overview of the steps you must perform in the prescribed order.

#### No configuration via Sunny Explorer

Sunny Explorer does not support the configuration of inverters with integrated web server and their own user interface. The inverter can be detected via Sunny Explorer, however it is expressly not recommended to use Sunny Explorer to configure this inverter. SMA Solar Technology AG does not accept liability for missing or incorrect data and possibly resulting yield losses.

- Use the integrated inverter user interface for the configuration of the inverter.

Procedure	See
1. Perform initial configuration with the help of the installation assistant.	Section 9.2, page 41
2. In order to receive control commands of the grid operator via SMA Speedwire/Webconnect for PV systems in Italy, set the parameters.	Section 9.4, page 42
3. If the inverter is installed in an IT network or another grid configuration where deactivation of the grounding conductor monitoring is required, deactivate the grounding conductor monitoring.	Section 9.5, page 43
4. For partially shaded PV modules and depending on the given shading situation, you should set the interval at which the inverter optimizes the MPP of the PV system.	Section 9.6, page 43
5. Make further settings where necessary.	

### 9.2 Starting the Installation Assistant

#### QUALIFIED PERSON

The installation assistant leads you step-by-step through the steps necessary for the initial configuration of the inverter.

#### Requirements:

- When configuring after completion of the first ten operating hours, the SMA Grid Guard code must be available (see "Application for SMA Grid Guard Code" at [www.SMA-Solar.com](http://www.SMA-Solar.com)).

#### Procedure:

1. Call up the inverter user interface (see Section 8.1, page 34).
2. Log in as **Installer**.

3. On the right-hand side of the menu bar, select the menu **User Settings** (see Section 8.2 "Design of the Inverter User Interface", page 37).
  4. In the subsequent context menu, select [**Start the installation assistant**].
- The installation assistant dialog opens.

## 9.3 Starting the Self-Test (For Italy Only)

### QUALIFIED PERSON

The self-test is only required for inverters to be commissioned in Italy. The Italian standard requires that all inverters feeding into the utility grid are equipped with a self-test function in accordance with CEI 0-21. During the self-test, the inverter will consecutively check the reaction times for overvoltage, undervoltage, maximum frequency and minimum frequency.

The self-test changes the upper and lower disconnection values for each protective function on a linear basis for frequency monitoring and voltage monitoring. As soon as the measured value exceeds the permitted disconnection threshold, the inverter disconnects from the utility grid. In this way, the inverter determines the reaction time and checks itself.

After the self-test has been completed, the inverter automatically switches back to feed-in operation, resets the original disconnection conditions and connects to the utility grid. The test takes approximately three minutes.

#### Requirements:

- The country data set of the inverter must be set to **CEI 0-21 internal**.

#### Procedure:

1. Call up the inverter user interface (see Section 8.1, page 34).
2. Log in as **Installer**.
3. Select the menu **System Configuration**.
4. Select [**Settings**].
  - A context menu opens.
5. Select [**Start self-test**] in the context menu.
6. Observe the instructions shown in the dialog and save the report of the self-test, if necessary.

## 9.4 Activating the Receipt of Control Signals (Only for Italy)

### QUALIFIED PERSON

In order for PV systems in Italy to receive control commands from the grid operator, set the following parameters. Some function-sensitive parameters can only be viewed by qualified persons and can only be changed by qualified persons.

The basic procedure for changing operating parameters is explained in another section (see Section 9.14 "Changing Operating Parameters", page 46).

Parameter	Value/range	Resolution	Default
Application ID	0 ... 16384	1	16384
GOOSE-Mac address	01:0C:CD:01:00:00 ... 01:0C:CD:01:02:00	1	01:0C:CD:01:00:00

#### Procedure:

1. Select the parameter group **External Communication > IEC 61850 configuration**.
  2. In the field **Application ID**, enter the application ID of the grid operator gateway. You will receive this value from your grid operator. You can enter a value between 0 and 16384. The value 16384 indicates "deactivated".
  3. In the field **GOOSE-Mac address**, enter the MAC address of the grid operator gateway from which the inverter is to receive the control commands. You will receive this value from your grid operator.
- The receipt of control signals from the grid operator is activated.

## 9.5 Deactivating Grounding Conductor Monitoring

### QUALIFIED PERSON

If the inverter is to be installed in an IT network or another grid configuration in which deactivation of the grounding conductor monitoring is required, deactivate the grounding conductor monitoring as follows.

The basic procedure for changing operating parameters is explained in another section (see Section 9.14 "Changing Operating Parameters", page 46).

#### Procedure:

- Set the parameter **PE connection monitoring** to **Off**.

## 9.6 Setting SMA OptiTrac Global Peak

### QUALIFIED PERSON

For partially shaded PV modules, you should set the interval at which the inverter is to optimize the MPP of the PV system.

The basic procedure for changing operating parameters is explained in another section (see Section 9.14 "Changing Operating Parameters", page 46).

#### Procedure:

- Select the parameter **Cycle time of the OptiTrac Global Peak algorithm** or **MPPShdw.CycTms** and set the required time interval. The ideal time interval is usually six minutes. This value should only be increased if the shading situation changes extremely slowly.
- The inverter optimizes the MPP of the PV system at the predetermined time interval.

## 9.7 Saving the Configuration in a File

You can save the current configuration of the inverter in a file. You can use this file as a data backup for this inverter and then import this file into this inverter again or another inverter to configure the inverter. When saving, only the device parameters will be saved, not the network configuration or any passwords.

### Procedure:

1. Call up the inverter user interface (see Section 8.1, page 34).
2. Log in as **Installer** or **User**.
3. Select the menu **System Configuration**.
4. Select [**Settings**].
  - A context menu opens.
5. In the context menu, select [**Saving the configuration in a file**].
6. Follow the instructions in the dialog.

## 9.8 Adopting a Configuration from a File

### QUALIFIED PERSON

To configure the inverter, you can adopt the configuration from a file. To be able to do this, you must first save the configuration of another inverter in a file (see Section 9.7 "Saving the Configuration in a File", page 44).

### Requirements:

- The SMA Grid Guard code must be available (see "Application for SMA Grid Guard Code" at [www.SMA-Solar.com](http://www.SMA-Solar.com)).
- Changes to grid-relevant parameters must be approved by the responsible grid operator.

### Procedure:

1. Call up the inverter user interface (see Section 8.1, page 34).
2. Log in as **Installer**.
3. Select the menu **System Configuration**.
4. Select [**Settings**].
  - A context menu opens.
5. In the context menu, select [**Adopting the configuration from a file**].
6. Follow the instructions in the dialog.

## 9.9 Updating the Firmware

You can manually update the inverter firmware. To do this, proceed as follows.

Tip: With PV systems that are registered in Sunny Portal, the inverter firmware is usually updated automatically. In certain circumstances, a manual update of the inverter firmware is, however, necessary.

**Requirements:**

- An update file with the current inverter firmware must be available. The update file is, for example, available for download on the product page of the inverter at [www.SMA-Solar.com](http://www.SMA-Solar.com).

**Procedure:**

1. Call up the inverter user interface (see Section 8.1, page 34).
2. Log in as **Installer** or **User**.
3. Select the menu **System Configuration**.
4. Select [**Settings**].
  - A context menu opens.
5. In the context menu, select [**Updating the firmware**].
6. Follow the instructions in the dialog.

## 9.10 Integrating the Inverter into the Network

**Requirements:**

- The inverter must be in operation.
- There must be a router with Internet connection in the local network of the system.

**Procedure:**

1. Call up the inverter user interface (see Section 8.1, page 34).
2. Log in as **Installer**.
3. On the right-hand side of the menu bar, select the menu **User Settings** (see Section 8.2 "Design of the Inverter User Interface", page 37).
4. In the subsequent context menu, select [**Start the installation assistant**].
5. Perform the desired network configuration.

## 9.11 Setting the Date and Device Time

You can set the date and the device time of the inverter.

**Procedure:**

1. Call up the inverter user interface (see Section 8.1, page 34).
2. Log in as **Installer** or **User**.
3. In the status bar at the bottom, click on the date and the time.
4. In the subsequent dialog, perform the desired settings for the date and device time.

## 9.12 Configuring the Energy Meter

**⚠ QUALIFIED PERSON**

You can add an energy meter to your PV system or replace an existing energy meter.

### Removing a detected energy meter from the PV system

If only one energy meter is detected by the inverter, this will be added to the PV system automatically. Removal via the menu **System Configuration** is not possible in this case. To remove the energy meter from the PV system, proceed as follows:

- In the parameter group **PV system communication > Measured values > Meter on Speedwire** set the parameter **Serial Number** to any number (e.g. 1) (see Section 9.1.4 "Changing Operating Parameters", page 46). In this way, instead of the energy meter detected, the PV system will add a fictitious energy meter to which the inverter can not establish communication.

#### Procedure:

1. Call up the inverter user interface (see Section 8.1, page 34).
2. Log in as **Installer**.
3. On the right-hand side of the menu bar, select the menu **User Settings** (see Section 8.2 "Design of the Inverter User Interface", page 37).
4. In the subsequent context menu, select [**Start the installation assistant**].
5. Select [**Save and next**] until you arrive in the menu **Meter configuration**.
6. Add or replace the desired energy meter.

## 9.13 Configuring Feed-In Management

### QUALIFIED PERSON

If required by the grid operator, the inverter can provide grid management services. You can configure these via the inverter feed-in management. Coordinate the configuration of the feed-in management with your grid operator beforehand.

#### Procedure:

1. Call up the inverter user interface (see Section 8.1, page 34).
2. Log in as **Installer**.
3. On the right-hand side of the menu bar, select the menu **User Settings** (see Section 8.2 "Design of the Inverter User Interface", page 37).
4. In the subsequent context menu, select [**Start the installation assistant**].
5. Select [**Save and next**] until you arrive in the menu **Feed-in management**.
6. Configure the feed-in management as desired.

## 9.14 Changing Operating Parameters

The operating parameters of the inverter are set to certain values by default. You can change the operating parameters to optimize the performance of the inverter.

This section describes the basic procedure for changing operating parameters. Always change operating parameters as described in this section. Some function-sensitive parameters can only be viewed by qualified persons and can only be changed by qualified persons by entering the personal SMA Grid Guard code.

### **No configuration via Sunny Explorer**

Sunny Explorer does not support the configuration of inverters with integrated web server and their own user interface. The inverter can be detected via Sunny Explorer, however it is expressly not recommended to use Sunny Explorer to configure this inverter. SMA Solar Technology AG does not accept liability for missing or incorrect data and possibly resulting yield losses.

- Use the integrated inverter user interface for the configuration of the inverter.

### **Requirements:**

- The changes to the grid-relevant parameters must be approved by the grid operator.
- When changing grid-relevant parameters, the SMA Grid Guard code must be available (see "Application for SMA Grid Guard Code" at [www.SMA-Solar.com](http://www.SMA-Solar.com)).

### **Procedure:**

1. Call up the inverter user interface (see Section 8.1, page 34).
2. Log in as **Installer** or **User**.
3. Call up the menu **Device Parameters**.
4. Select [**Edit parameters**].
5. Log in using the SMA Grid Guard code to change those parameters designated by a lock (only for installers):
  - On the right-hand side of the menu bar, select the menu **User Settings** (see Section 8.2 "Design of the Inverter User Interface", page 37).
  - In the subsequent context menu, select [**SMA Grid Guard login**].
  - Enter the SMA Grid Guard code and select [**Login**].
6. Change the desired parameters.
7. Select [**Save all**] to save the changes.

## 9.15 Configuring the Country Data Set

### **QUALIFIED PERSON**

By default, the inverter is set to a universally valid country data set. You can adjust the country data set for the installation site retroactively.

The basic procedure for changing operating parameters is explained in another section (see Section 9.14 "Changing Operating Parameters", page 46).

### **Procedure:**

- Select the parameter **Set country standard** and set the required country data set.

## 9.16 Switching the Dynamic Power Display Off

As standard, the inverter signals its power dynamically via the pulsing of the green LED. When doing so, the LED flashes on and off uniformly or is permanently lit at full power. The various gradations are related here to the set active power limit of the inverter. If this display is not desired, switch this function off in accordance with the following procedure. Once this has been done, the green LED is only lit permanently to signalize feed-in operation.

The basic procedure for changing operating parameters is explained in another section (see Section 9.14 "Changing Operating Parameters", page 46).

### Procedure:

- In the parameter group **Device > Operation**, select the parameter **Dynamic power display via green LED** and set this to **Off**.

## 9.17 Switching WLAN Off

The inverter is equipped with an activated WLAN interface as standard. If you do not want to use WLAN, you can switch the WLAN function off in accordance with the following procedure. In doing so, you can switch the WLAN direct connection and the WLAN connection in the local network on or off independently of each other. If you would like to switch the WLAN function off completely, you must switch off both the WLAN direct connection and the WLAN connection in the local network.

The basic procedure for changing operating parameters is explained in another section (see Section 9.14 "Changing Operating Parameters", page 46).

### **i** Switching on the WLAN function only possible via Ethernet connection

If you switch off both the WLAN function for the WLAN direct connection and for the WLAN connection in the local network, access to the inverter user interface and therefore reactivation of the WLAN interface is only possible via an Ethernet connection.

### Procedure:

- To switch off the WLAN direct connection, select the parameter **Soft-access-point is turned on** and set this to **No**.
- To switch off the WLAN connection in the local network, select the parameter **WLAN is turned on** and set this to **No**.

## 9.18 Switching WLAN On

If you have switched the WLAN function for direct connection or for connection in the local network off, you can switch the WLAN function back on in accordance with the following procedure. In doing so, you can switch the WLAN direct connection and the WLAN connection in the local network on independently of each other.

The basic procedure for changing operating parameters is explained in another section (see Section 9.14 "Changing Operating Parameters", page 46).

### Requirement:

- If the WLAN function was previously switched off completely, the inverter must be connected to a computer or router via Ethernet.



**Procedure:**

- To switch on the WLAN direct connection, in the parameter group **PV system communication > WLAN**, select the parameter **Soft-access-point is turned on** and set this to **Yes**.
- To switch on the WLAN connection in the local network, in the parameter group **PV system communication > WLAN**, select the parameter **WLAN is turned on** and set this to **Yes**.

## 10 Disconnecting the Inverter from Voltage Sources

### ⚠ QUALIFIED PERSON

Prior to performing any work on the inverter, always disconnect it from all voltage sources as described in this section. Always adhere to the prescribed sequence.

#### Procedure:

1. Disconnect the circuit breaker and secure it against reconnection.
2. If an external DC load-break switch is installed, disconnect the external DC load-break switch from all voltage sources.
3. Set the DC load-break switch of the inverter to 

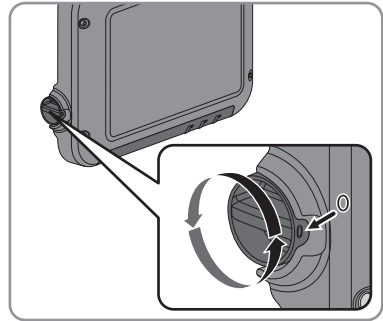

4. Wait until the LEDs have gone out.
5. Use a current clamp to ensure that no current is present in the DC cables.
6. Release and remove all DC connectors. To do this, insert a flat-blade screwdriver or an angled screwdriver (blade width 3.5 mm) into one of the slide slots and pull the DC connectors out in a downward direction. Do not pull on the cable.

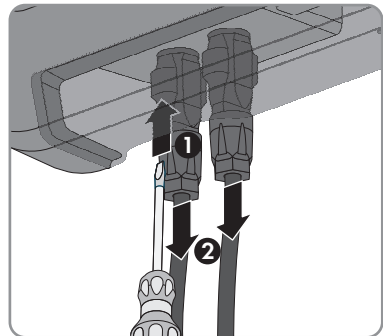

- 7. Ensure that no voltage is present at the DC inputs on the inverter using a suitable measuring device.

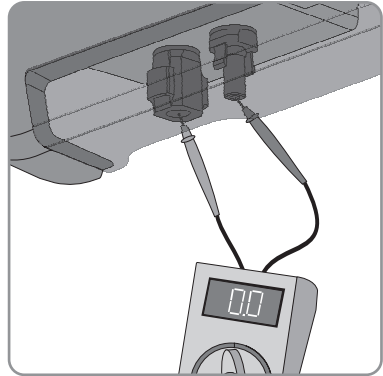

- 8. Loosen the swivel nuts.
- 9. Loosen the screws of the connection cap and remove the connection cap.

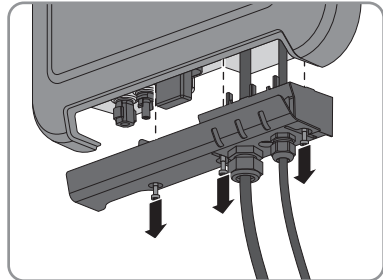

- 10. Use a suitable measuring device to check that no voltage is present at the AC connector between L and N and between L and the grounding conductor. To do so, insert the test probe (maximum diameter: 2 mm) into each round opening of the connecting terminal plate.
- 11. Release and disconnect the AC connector using the sliders located on the side.

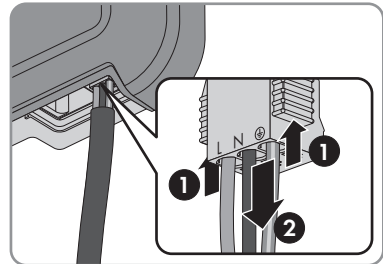

# 11 Technical Data

## DC Input

	SB 1.5-1VL-40	SB 2.5-1VL-40
Maximum DC power at $\cos \varphi = 1$	1,600 W	2,650 W
Maximum input voltage	600 V	600 V
MPP voltage range	160 V to 500 V	260 V to 500 V
Rated input voltage	360 V	360 V
Minimum input voltage	50 V	50 V
Start input voltage	80 V	80 V
Maximum input current	10 A	10 A
Maximum short-circuit current*	18 A	18 A
Maximum reverse current from the inverter in the system for max. 1 ms	0 A	0 A
Number of independent MPP inputs	1	1
Oversvoltage category in accordance with IEC 60664-1	II	II

\* In accordance with IEC 62109-2:  $I_{SC PV}$

## AC Output

	SB 1.5-1VL-40	SB 2.5-1VL-40
Rated power at 230 V, 50 Hz	1,500 W	2,500 W
Maximum apparent AC power at $\cos \varphi = 1$	1,500 VA	2,500 VA
Rated grid voltage	230 V	230 V
Nominal AC voltage	220 V / 230 V / 240 V	220 V / 230 V / 240 V
AC voltage range*	180 V to 280 V	180 V to 280 V
Nominal AC current at 220 V	7 A	11 A
Nominal AC current at 230 V	6.5 A	11 A
Nominal AC current at 240 V	6.25 A	10.5 A
Maximum output current	7 A	11 A
Total harmonic distortion of the output current with total harmonic distortion of the AC voltage < 2%, and AC power > 50% of the rated power	≤3 %	≤3 %

	<b>SB 1.5-1VL-40</b>	<b>SB 2.5-1VL-40</b>
Maximum output current under fault conditions	12 A	19 A
Inrush current	< 20% of the nominal AC current for a maximum of 10 ms	< 20% of the nominal AC current for a maximum of 10 ms
Rated power frequency	50 Hz	50 Hz
AC power frequency*	50 Hz / 60 Hz	50 Hz / 60 Hz
Operating range at AC power frequency 50 Hz	45 Hz to 55 Hz	45 Hz to 55 Hz
Operating range at AC power frequency 60 Hz	55 Hz to 65 Hz	55 Hz to 65 Hz
Power factor at rated power	1	1
Displacement power factor $\cos \varphi$ , adjustable	0.8 underexcited to 1 to 0.8 overexcited	0.8 underexcited to 1 to 0.8 overexcited
Feed-in phases	1	1
Connection phases	1	1
Overvoltage category in accordance with IEC 60664-1	III	III

\* depending on the configured country data set

## Protective Devices

DC reverse polarity protection	Short-circuit diode
Input-side disconnection point	DC Load-Break Switch
AC short-circuit current capability	Current control
Grid monitoring	SMA Grid Guard 6
Maximum permissible fuse protection	16 A
Ground fault monitoring	Insulation monitoring: $R_{i,so} > 1 \text{ M}\Omega$
All-pole sensitive residual-current monitoring unit	Available

## General Data

Width x height x depth	460 mm x 357 mm x 122 mm
Weight	9.2 kg
Length x width x height of the packaging	597 mm x 399 mm x 238 mm
Weight including packaging	11.5 kg

Climatic category in accordance with IEC 60721-3-4	4K4H
Environmental category	Outdoors
Pollution degree outside the inverter	3
Pollution degree inside the inverter	2
Operating temperature range	-40 °C to +60 °C
Maximum permissible value for relative humidity, non-condensing	100 %
Maximum operating altitude above mean sea level	3,000 m
Noise emission, typical	< 25 dB
Power loss in night mode	2 W
Maximum data volume per inverter with Speedwire/Webconnect	550 MB/month
Additional data volume when using the Sunny Portal live interface	600 kB/hour
WLAN range in free-field conditions	100 m
Quantity maximum detectable WLAN networks	32
Topology	Transformerless
Cooling method	Convection
Degree of protection in accordance with IEC 60529	IP65
Protection class in accordance with IEC 62103	I
Grid configurations	TN-C, TN-S, TN-CS, TT (if $V_{N,PE} < 30$ V), IT, Delta IT, split phase
National standards and approvals, as per 04/2015*	AS 4777, C10/11/2012, CEI 0-21, EN 50438:2013, G83/2, NEN-EN50438, VDE-AR-N 4105, VFR2014, DIN EN 62109-1, IEC 62109-2

\* **IEC 62109-2:** In order to meet the requirements of this standard, there must be a link to Sunny Portal with the fault alert via e-mail activated.

## Climatic Conditions

### Installation in accordance with IEC 60721-3-4, Class 4K4H

Extended temperature range	-40 °C to +60 °C
----------------------------	------------------

Extended humidity range	0 % ... 100 %
Extended air pressure range	79.5 kPa to 106 kPa

### Transport in accordance with IEC 60721-3-4, Class 2K3

Extended temperature range	-25 °C to +70 °C
----------------------------	------------------

### Equipment

DC connection	SUNCLIX DC connector
AC connection	Spring-cage terminal
Speedwire interface	As standard
Webconnect interface	As standard
WLAN	As standard

### DC Load-Break Switch

Electrical endurance in the event of short circuit, at nominal current of 10 A	At least 50 switching operations
Maximum switching current	35 A
Maximum switching voltage	800 V
Maximum PV power	11 kW

### Torques

Screws wall mounting	Hand-tight
Screws connection cap	3.5 Nm
SUNCLIX swivel nut	2.0 Nm
AC swivel nut	Hand-tight
Network swivel nut	Hand-tight
Additional grounding terminal	6.0 Nm

### Data Storage Capacity

Energy yields in the course of the day	63 days
Daily yields	30 years
Event messages for users	1,000 events
Event messages for installers	1,000 events

**Efficiency**

	<b>SB 1.5-1VL-40</b>	<b>SB 2.5-1VL-40</b>
Maximum efficiency, $\eta_{\max}$	97.2 %	97.2 %
European weighted efficiency, $\eta_{\text{EU}}$	96.1 %	96.7 %



**SMA Solar Technology**

**[www.SMA-Solar.com](http://www.SMA-Solar.com)**

